

# SYSTEM SOLUTIONS FOR STRUCTURAL GLAZING

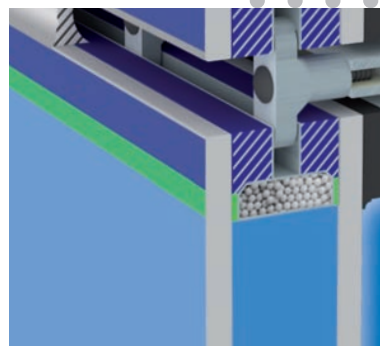

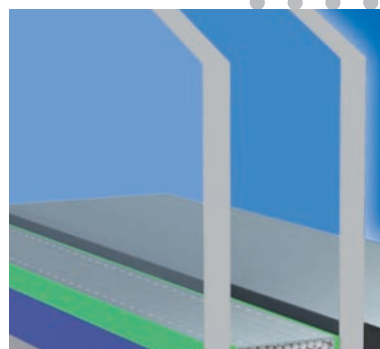
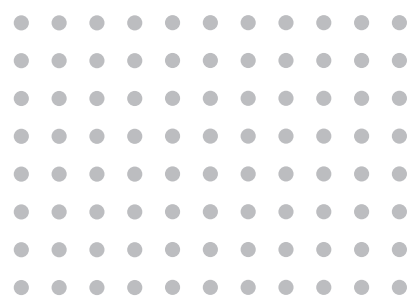

## STRUCTURAL GLAZING

Unlike any other material glass is beautiful, timeless and elegant. Its use in modern architecture has enhanced our city centres for decades. On one hand the facades must satisfy the highest aesthetic demands. On the other, as a technically demanding system, they must fulfil many functions in the building. With all-glass facades in Structural Glazing construction these requirements can be combined in an ideal way. They have excellent resistance against extreme climate conditions and provide long-term durability coupled with an enhanced aesthetic appearance. Structural Glazing is an assembly technique used in facade engineering, where the glass elements are bonded to the supporting aluminium or stainless steel structure using specially developed high performance Silicone adhesives. Static and dynamic weight loads on the outside facade such as dead load, climate and wind loads are transferred to the substructure by the structural bonding.

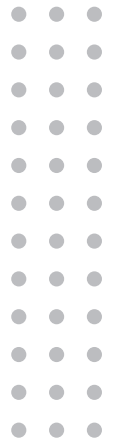

### TWO-SIDED STRUCTURAL GLAZING SYSTEM

Two opposite glass edges are bonded to the load bearing framework. The two other edges are fixed mechanically by securing profiles. The bonding can occur vertically as well as horizontally. The dynamic loads will be absorbed from the Structural Glazing Silicone whereas the dead load will be transferred to the securing profiles.

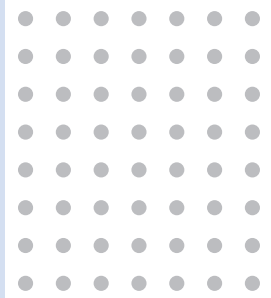
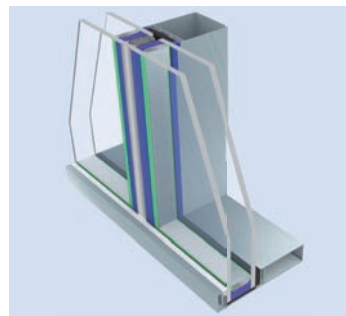

### FOUR-SIDED STRUCTURAL GLAZING SYSTEM

All four sides of the glass elements are bonded to a frame which will be subsequently attached to the substructure on site. Depending on the construction the dead load will be transferred either mechanically or through the Structural Glazing Silicone. With a four-sided Structural Glazing system, no mounting will be visible from the outside. The result is an aesthetically pleasing all-glass facade.

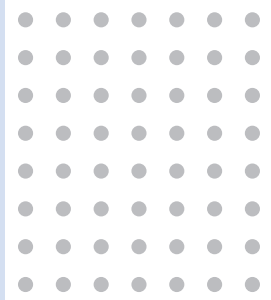
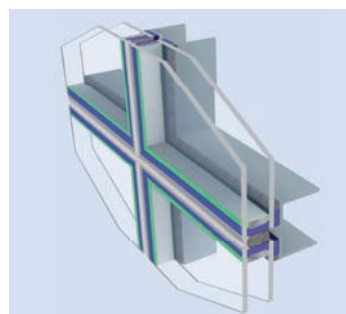

## GD 920 / KÖDIGLAZE S ADHESIVES FOR STRUCTURAL GLAZING

In addition to the regular SG system there is increasing use of the so-called U-Profile-System, which allows the fixing of the insulating glass units to the substructure. Here the aluminium or stainless steel U-profiles are embedded into the secondary sealing during fabrication. The mechanical fixing is made with the use of fixing points, which are adapted into the integrated U-Profile. The secondary sealing can be made with Ködiglaze S or GD 920 depending on the intended application. Each system provider has their own unique system.

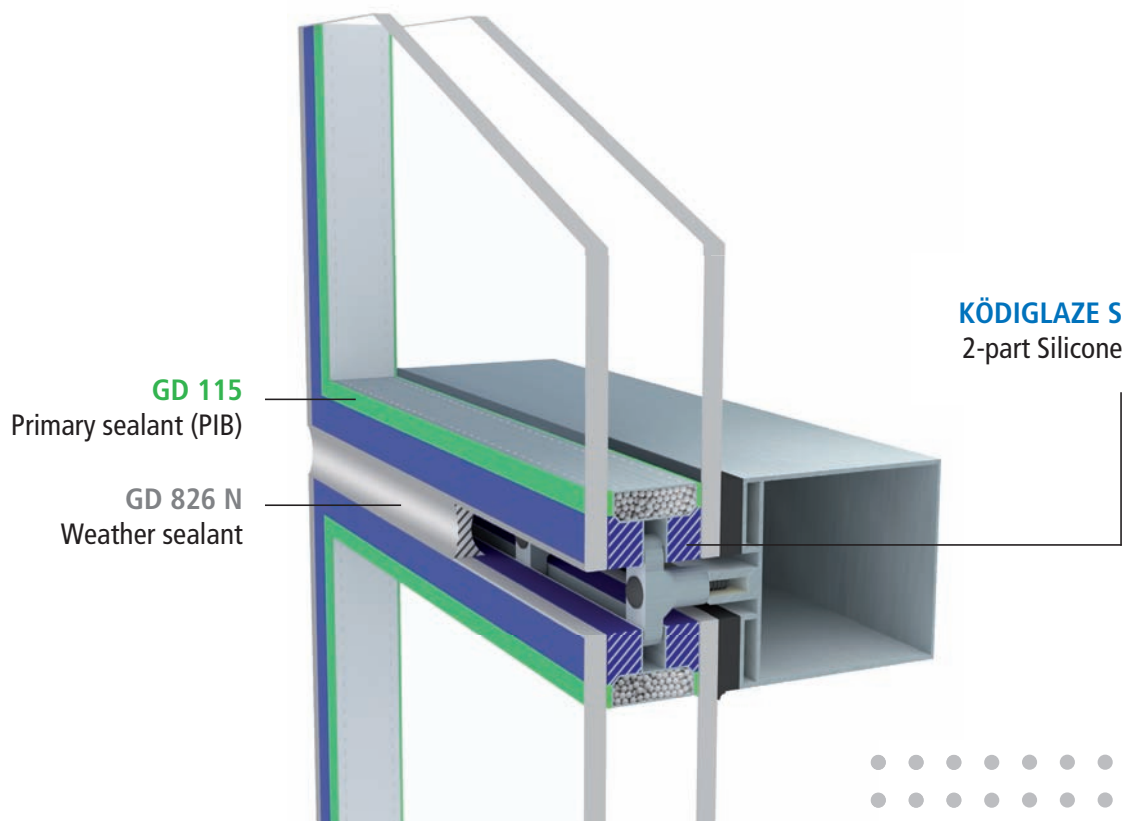

## SECONDARY SEALANT / SG ADHESIVE KÖDIGLAZE S

### Ködiglaze S

**2-part Silicone adhesive for Structural Glazing and insulating glass applications, also for unsupported systems**

- High mechanical strength and elasticity
- Neutral curing system
- Excellent weathering and UV resistance
- For automated processing
- Meets the requirements of EN 1279 part 2 and part 3
- Label ETA 08/0286 (ETAG 002)
- Label SNJF VEC
- Label CE

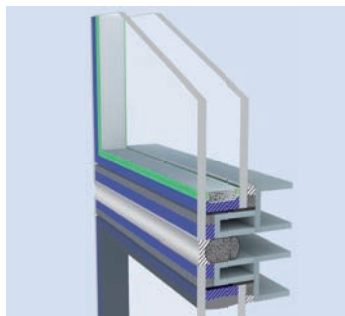

## SECONDARY SEALANT GD 920

### GD 920

**2-part Silicone Sealant as secondary sealant for the manufacturing of insulating glass for mechanically supported systems**

- High strength
- Excellent weathering and UV resistance
- For automated processing
- For all types of IG in the facade construction
- High modulus
- Meets the requirements of EN 1279 part 2 and part 3
- Label ETA 08/0004 (ETAG 002)
- Label SNJF VI-VEC
- Label CE

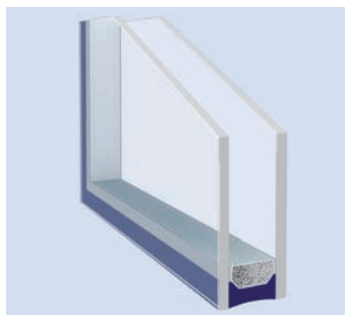

## WEATHER SEALANT GD 826 N

### GD 826 N

**1-part Silicone Sealant for weather sealing**

- Excellent weathering resistance
- Excellent UV resistance
- Elastic with high movement capacity
- Neutral curing system
- Meets the requirements of DIN 18545
- Proven compatibility with KÖMMERLING SG-Silicones according to ETAG 002

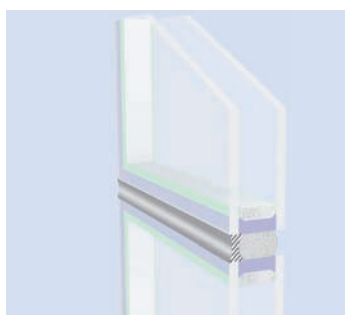

## WARM-EDGE-SYSTEM KÖDISPACE 4SG

The use of Ködispace 4SG, the new generation of thermoplastic Warm-Edge-System, allows the complete substitution of conventional spacer systems, these usually consist of a metal or plastic spacer, desiccant and primary sealant. Ködispace 4SG in contrast is a polymer matrix with integrated desiccant, which meets the high requirements regarding long term stability and in particular the demands for gas tightness of insulating glass units with silicone secondary sealant.

Ködispace 4SG is fast setting and gives good initial adhesion, which is followed by the development of strong chemical bonds to the glass and silicone secondary sealants thus providing excellent long term stability. This makes Ködispace 4SG a very robust and resilient Warm-Edge-System, especially suitable for Structural Glazing applications in areas with extreme temperatures.

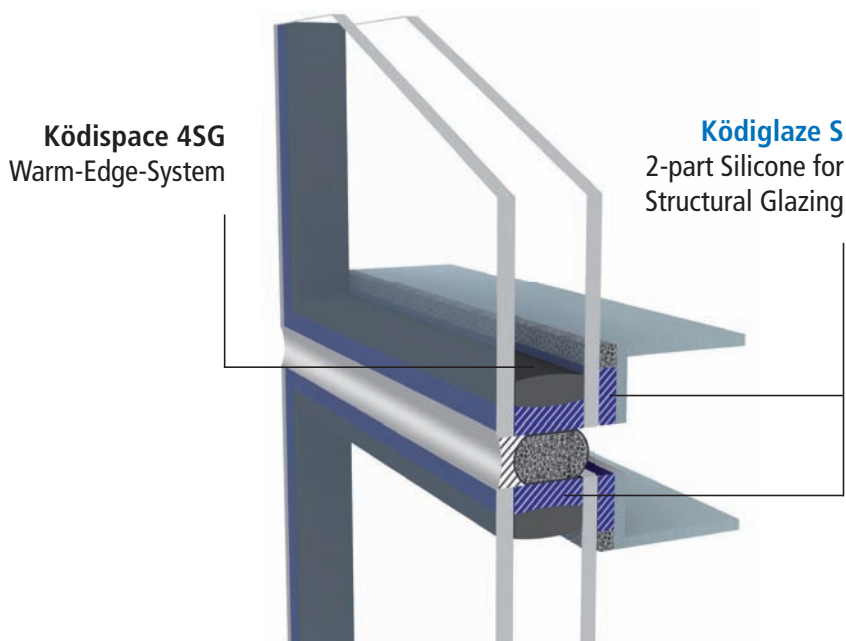

### **Ködispace 4SG**

**Warm-Edge-System for the manufacturing of insulating glass units, particularly for those units used in Structural Glazing applications**

- Greater adhesion to glass and silicone secondary sealants
- Very low water vapour transmission rate and gas permeability
- Low thermal conductivity
- Meets the requirements of EN 1279 part 2 and part 3 in combination with GD 920 or Ködiglaze S
- Proven compatibility with KÖMMERLING SG-Silicones according to ETAG 002

## BUTYL PRIMARY SEALANT GD 115

### GD 115

#### Thermoplastic synthetic rubber (PIB) for the primary sealing of insulating glass units

- Very low water vapour transmission and gas permeation rate
- Good adhesion properties to glass and spacer
- Proven compatibility with KÖMMERLING SG Silicones according to ETAG 002

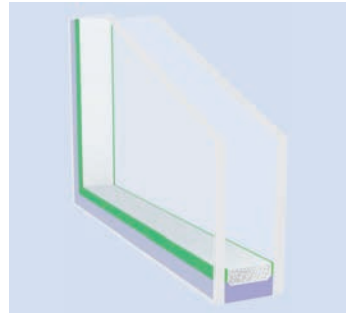

## ANCILLARIES PRIMERS AND CLEANERS

The most important factor in a successful Structural Glazing application is the reliable bonding of the adhesive to the material surface. To ensure this, the surface has to be thoroughly cleaned before bonding. The adhesion between substrate and adhesive can be improved by the use of a primer. For this purpose KÖMMERLING offers primers and cleaners which are specially developed for the pre-treatment of metal and glass surfaces and adapted to the materials to be bonded as well as to the KÖMMERLING-Silicones for Structural Glazing.

### Körabond HG 78

Primer for the pre-treatment of anodized aluminium or stainless steel

### Körasolv GL

Cleaner for anodized aluminium, stainless steel and glass

### Körasolv WL

Cleaner for powder coated aluminium

### Körasolv Silicone

Cleaner for 2-part-Silicone mixing and dosing machines

### Köralub SI

Lubricant for seals, plungers and cylinders of silicone application machines



# KÖMMERLING COMPETENCE AND SERVICE

Structural Glazing projects are becoming more and more demanding not only in their architectural aspects, but also in the technical requirements. To ensure the success of the application close cooperation between the architects, facade manufacturers and suppliers from the glass, adhesives and sealants industry is essential.

KÖMMERLING offers a complete product range for the glass industry, including Structural Glazing Silicones and the Warm-Edge-System Ködispace 4SG, as well as other insulating glass sealants based on butyl, polysulphide, polyurethane and silicone. All materials are matched to each other. With these system solutions from one source KÖMMERLING ensures the highest level of safety for the system.

KÖMMERLING considers itself to be a system supplier, not only providing high quality products but also offering an individual consulting service and support throughout the duration of the project working in partnership with its customers.

## OUR SERVICE

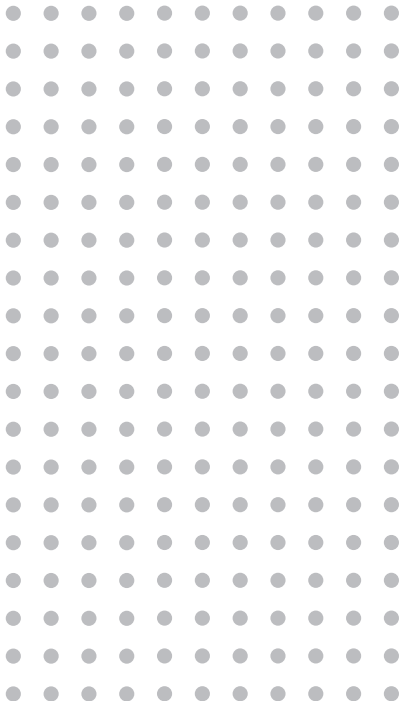
- Approval of the joint design and calculation of the joint dimensions
  - Adhesion testing
  - Compatibility tests
  - Application training directly with the processor
  - Help when working with independent laboratories for external testing
  - Development of programs for quality assurance
- 

# KÖMMERLING – MORE THAN JUST A PRODUCT

## Our philosophy ...

### ... more research and development!

We have the solutions for tomorrow's requirements today.

### ... more products!

We have the widest product-range in the market.

### ... more logistics!

We help to save your time.

### ... more consulting and training!

We increase your benefit, your certainty and your income return.

### ... more service!

We are there when you need us.

### ... more communication!

We are active in building-up your market.

### ... more quality!

We offer you high performance products.

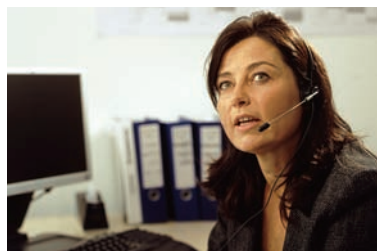
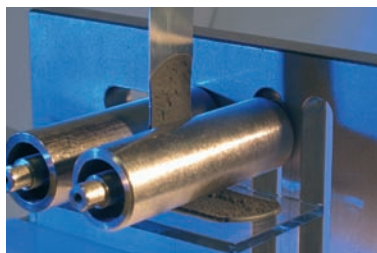

## KÖMMERLING

KÖMMERLING CHEMISCHE FABRIK GMBH

**Kömmerring Chemische Fabrik GmbH**  
Postfach 2162  
D-66929 Pirmasens  
Germany  
0049 6331 56-2000 phone  
0049 6331 56-1999 fax  
e-mail: klebstoffe@koe-chemie.de  
www.koe-chemie.de

**Kommerling UK Limited**  
27 Riverside Way, Uxbridge  
Middlesex UB8 2YF  
England  
0044-1895-465-600 phone  
0044-1895-465-617 fax  
e-mail: enquiries@kommerlinguk.com  
www.koe-chemie.com

**Kömmerring Chimie S.à.r.l.**  
7 rue des Corroyeurs  
F-67200 Strasbourg  
France  
0033 388 288359 phone  
0033 388 282223 fax  
e-mail: klebstoffe@koe-chemie.de  
www.koe-chemie.fr

**ADCO Products, Inc.**  
4401 Page Avenue  
P.O. Box 457  
Michigan Center, MI 49254  
001.800.248.4010 phone  
001.517.764.6697 fax  
e-mail: info@adcocorp.com  
www.adcocorp.com